

# PEAKCOLD

— P L U S + —

## 2 DOOR DISPLAY FREEZER

P-IM43MF2

Large Double Door with Eco-friendly HC Refrigerant with Spark-free Components.



### KEY FEATURES

- **Eco-Friendly Refrigerant**  
Environmentally friendly hydrocarbon refrigerant has low Global Warming Potential (GWP). Meets all USA & California refrigerant & energy standards.
- **Digital Temperature Display**  
electronic controller assures optimal refrigeration performance through precision temperature control.
- **High Power Reliable Refrigeration System**  
Fast pull down, optimal internal air circulation and reliable refrigeration, maintaining colder temperatures for food preservation.
- **Spark-Free Refrigeration Components**  
All models have spark free refrigeration components for optimal safety, per UL requirements.
- **Standard LED Lighting System**  
LED illumination system provides optimal merchandise display visibility.

### ROCK SOLID

## WARRANTY

No Headaches  
No Registration Required  
For PeakCold Plus Line

**PEAKCOLD**  
— PLUS + —

**5 YEAR ON COMPRESSORS**

**3 YEAR ON PARTS**

**3 YEAR ON LABOR**



**DOE**

### PRODUCT VIEWS

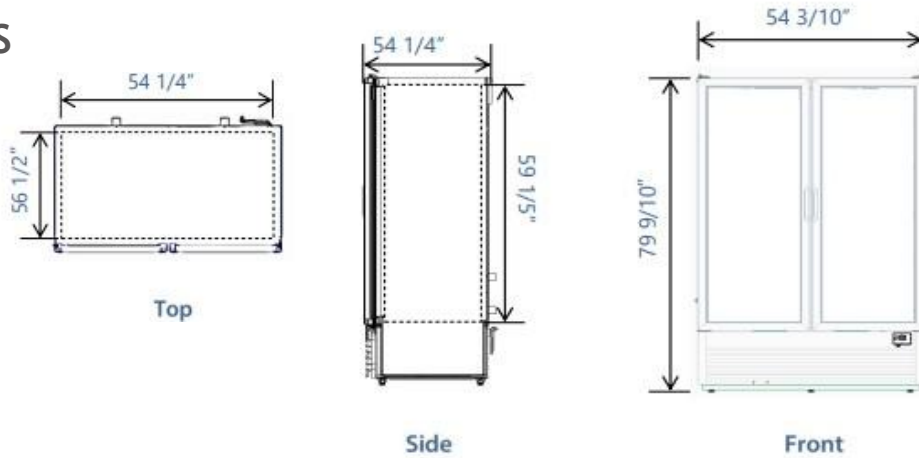

TECHNICAL SPECIFICATIONS		
<b>Exterior Dimensions</b>	<b>Usable Interior Capacity</b>	<b>Material</b>
H: 79 9/10" (200 cm)	H: 49 7/8" (127 cm)	Curved Plastic Frame
W: 54 3/10" (138 cm)	W: 47 1/2" (121 cm)	Shelves 8
D: 32 1/8" (82 cm)	D: 19 1/4" (49 cm)	Shelf Size 29 9/10" (53 cm)
<b>Interior Dimensions</b>	<b>Usable Volume</b>	W: 24 1/10" (61 cm)
H: 59 1/5" (150 cm)	41.86Ft3 / 1185.5 L	D: 19 3/5" (50 cm)
W: 54 1/4" (138 cm)	<b>Doors</b>	<b>Exterior Material</b> Pre-painted steel
D: 56 1/2" (144 cm)	2	<b>Interior Material</b> Pre-painted steel

REFRIGERATION PERFORMANCE	ELECTRICAL	LOGISTICS
<b>Refrigerant</b>	<b>Power Supply</b>	<b>Trailer Loads</b>
R290 / 7.8 oz (0.022 kg)	115V/60Hz	53': 33
<b>Compressor Power</b>	<b>Plug Type</b>	<b>Unit Weight</b>
1/2 HP	NEMA 5-15P	565.71 lb (256.6 kg)
<b>Thermostat default setting</b>	<b>Amps</b>	<b>Shipping Weight</b>
-11.2°F (-24°C) to -0.4°F (-18°C)	11.2 A	580.04 lb (263.1 kg)
<b>Energy Consumption</b>	<b>Controller</b>	<b>Shipping Dimensions</b>
12.772 kWh/24h	EC	H: 82 1/2" (210 cm)
<b>Condenser</b>	<b>Lighting</b>	W: 56 3/8" (143 cm)
Dynamic	6 modules, 144 LED	D: 31 1/2" (80 cm)
	<b>Cord Length</b>	
	118 1/10" (300 cm)	



This equipment is intended for the storage and display of bottled or canned products. This display refrigerator is not for the display of potentially hazardous foods.

- Warranties are not supported outside the continental United States
- All warranties valid from date of purchase and are not transferable to other parties.
- Warranties do not cover the loss of product or income due to equipment malfunction.
- Placing the equipment outdoors, using it to store hazardous materials or modifying the equipment in any way voids all warranties.