

Kegeerator Series

24" depth • 4 sizes



FEATURES

- Double tap stainless steel towers (3" diameter) and drip trays
- Keg couplers and hosing included
- Side knock out for exterior CO2 tanks
- Forced air tower cooling
- Left side mounted front venting compressor using R290 hydrocarbon refrigerant
- LED interior lighting
- Adjustable epoxy coated 90 lb. capacity shelves
- Dixell digital controller with automatic defrost programming
- Self-evaporating water tray – no drain needed
- ETL Listed and conforms to NSF Std. 7
- Standard 15 amp plug



Model	Doors	HP	Amps	Volume	½ Keg Capacity	Width	Depth	Height
IM36NDD	1	1/4	3	7.8 Cu Ft	1	Ext: 36.8" Int: 24.3"	Ext: 24.4" Int: 18.5"	Ext: 36.3" Int: 30.5"
IM48NDD2	2	1/5	2.88	11.8 Cu. Ft	2	Ext: 48.8" Int: 36.25"	Ext: 24.4" Int: 18.5"	Ext: 35.6" Int: 28.9"
IM60NDD2	2	1/5	2.88	15.8 Cu. Ft	2	Ext: 60.75" Int: 48.25"	Ext: 24.4" Int: 18.5"	Ext: 35.6" Int: 28.9"
IM72NDD3	3	1/4	3.96	19.6 Cu. Ft.	3	Ext: 72.75" Int: 60.1"	Ext: 24.4" Int: 18.5"	Ext: 35.6" Int: 28.9"

PEAKCOLD Kegerator Series

* Keg layouts are suggested. Air circulation must be maintained around each keg for proper cooling. Allow 24 hours for kegs to reach serving temperature.

IM36NDD

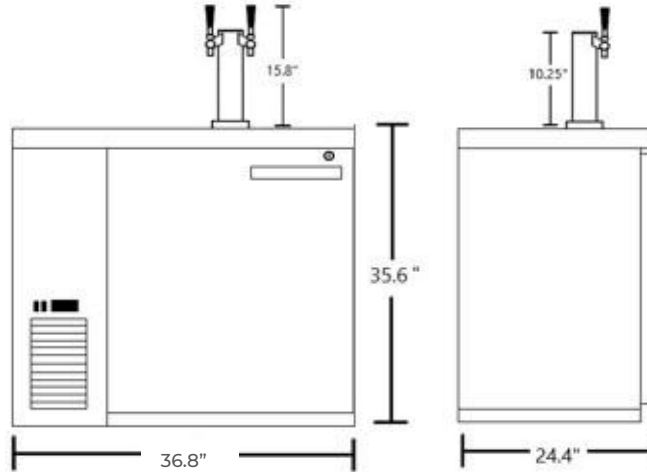

Keg layouts

1/2 kegs must be loaded through right side door

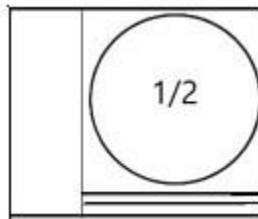

IM48NDD2

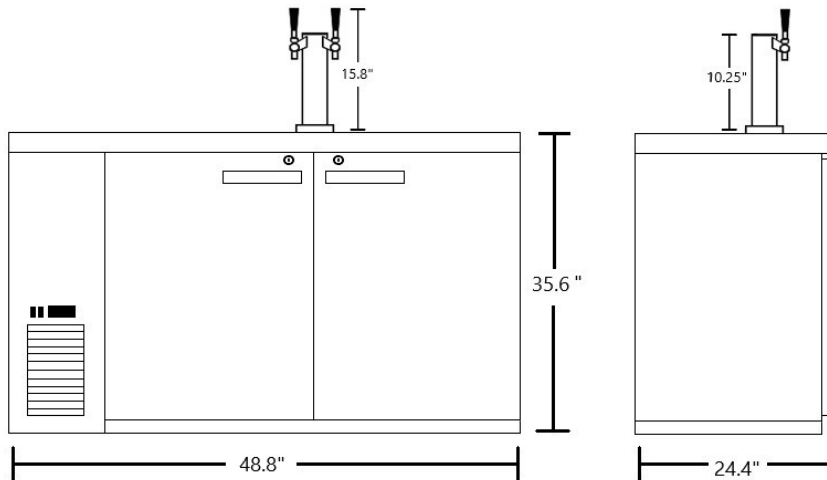

Keg layouts

1/2 kegs must be loaded through right side door

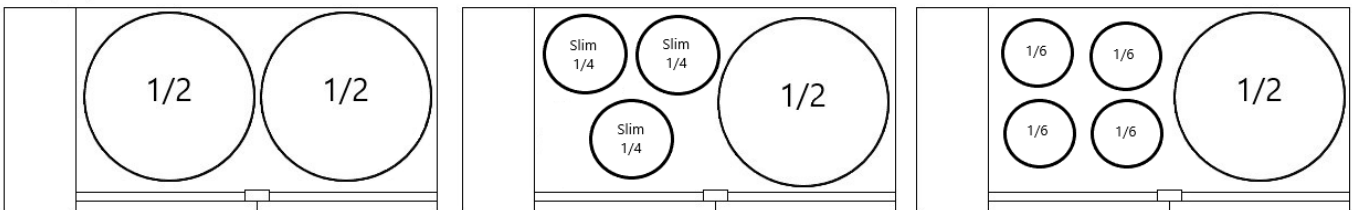

PEAKCOLD Kegerator Series

IM60NDD2

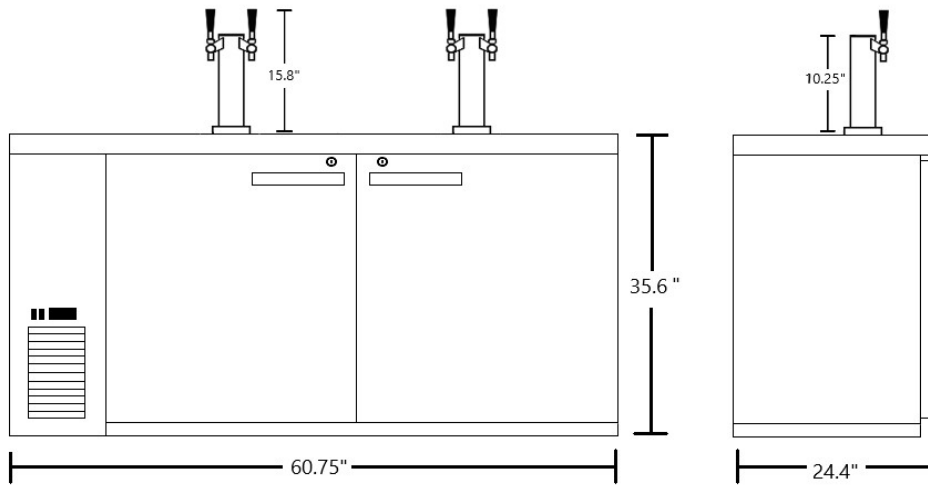

Keg layouts

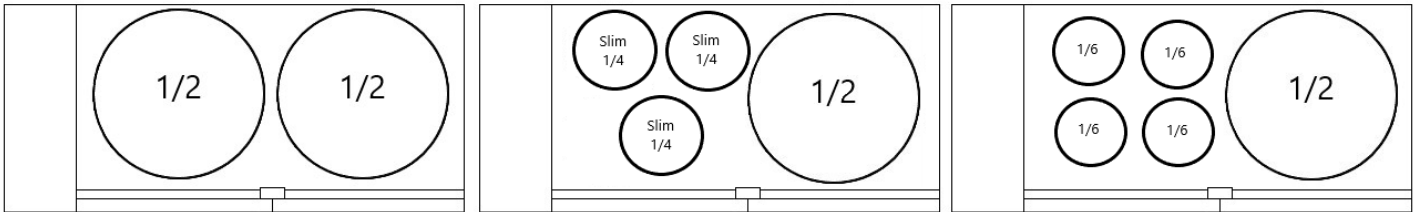

IM72NDD3

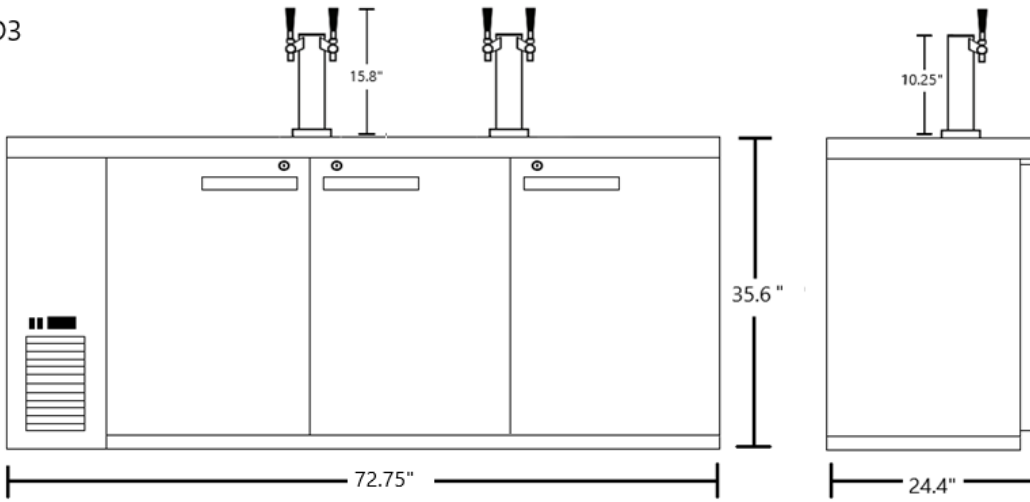

Keg layouts

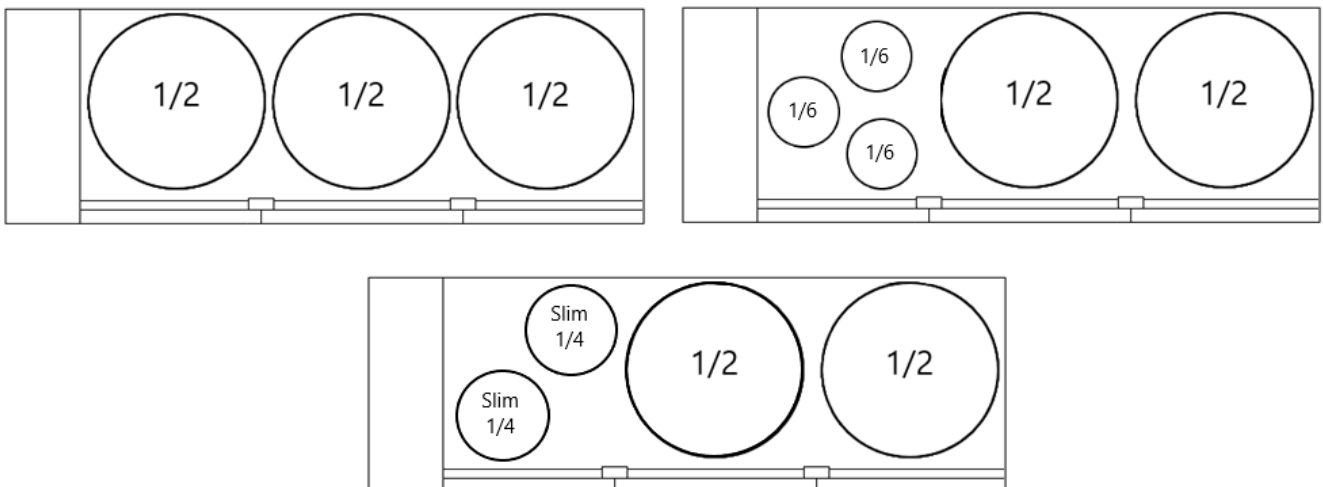

PEAKCOLD Kegerator Series