

Milk Coolers

▪ 3 sizes ▪



FEATURES

Powder coated steel exterior

Stainless steel interior

Stainless steel fold down front and flip top lid

Interior plug for easy draining after spills or cleaning

Heavy duty casters with locks

R290 environmentally friendly hydrocarbon refrigerant

Dixell digital controller with automatic defrost programming

ETL Listed and conforms to NSF Std. 7

Standard 15 amp plug



Model	# of Milk Crates	HP	Amps	Volume	Width	Depth	Height
IM34MC	8 crates	1/3	1.33	12.4 Cu. Ft	Ext: 34" Int: 30.9"	Ext: 30.6" Int: 27"	Ext: 41.4" Int: 25.75"
IM49MC	12 Crates	1/5	2.28	18.5 Cu. Ft	Ext: 49" Int: 45.9"	Ext: 30.6" Int: 27"	Ext: 41.4" Int: 25.75"
IM58MC	16 Crates	1/5	2.4	22.8 Cu. Ft	Ext: 58" Int: 54.9"	Ext: 30.6" Int: 27"	Ext: 41.4" Int: 25.75"

PEAKCOLD Milk Coolers

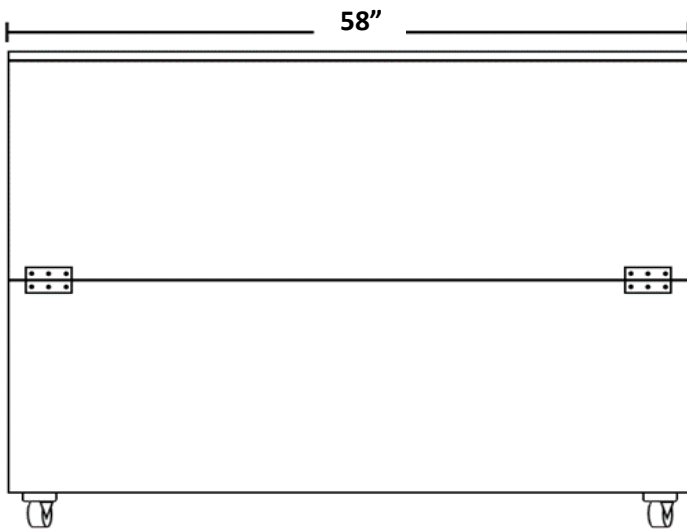
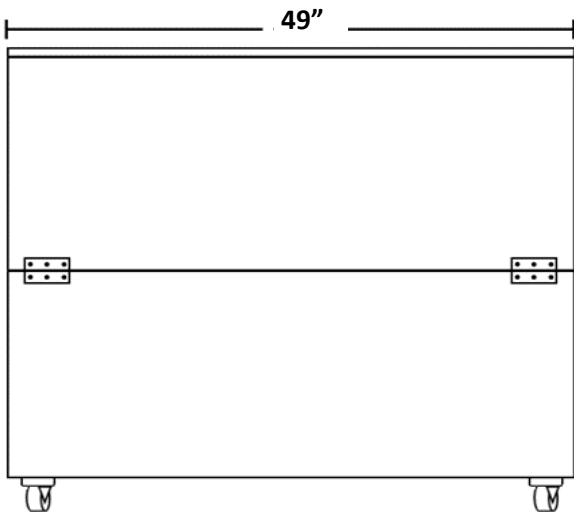
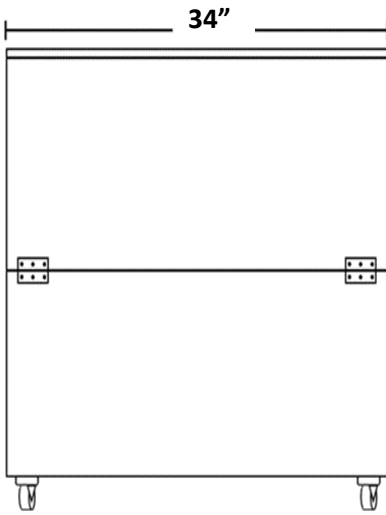

Side View All Sizes

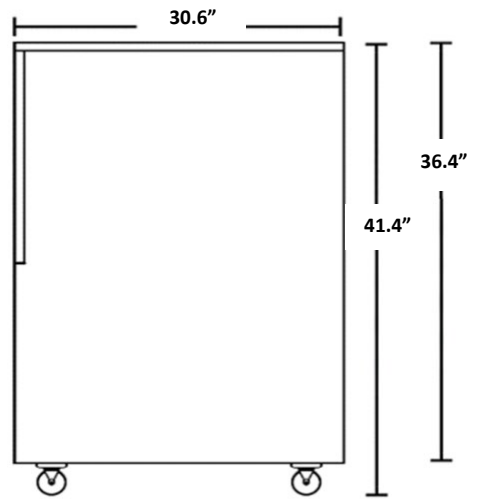

ROCK SOLID

WARRANTY

No Headaches
No Registration Required
For Procool and PeakCold Lines

PEAKCOLD®

5 YEAR ON COMPRESSORS

3 YEAR ON PARTS

1 YEAR ON LABOR

IRON MOUNTAIN
REFRIGERATION + EQUIPMENT

For warranty service, contact service@ironmountainrefrigeration.com or call 833-734-8880. Your warranty...

- is not supported outside the continental United States
- begins on the date of purchase and are not transferable to other parties.
- does not cover damage due to misuse, abuse, accidents, alterations or improper installation.
- does not cover normal wear and tear or cosmetic imperfections not reported at delivery.
- does not cover the loss of product or income due to equipment malfunction.

*Placing equipment outdoors, exposure to extreme temperatures, using it to store hazardous materials or modifying the equipment in any way voids all warranties.

Food Truck or Trailer Use Warranty: Customers installing equipment in a food truck or trailer shall receive 30 days of replacement warranty coverage, regardless of the standard coverage period.