

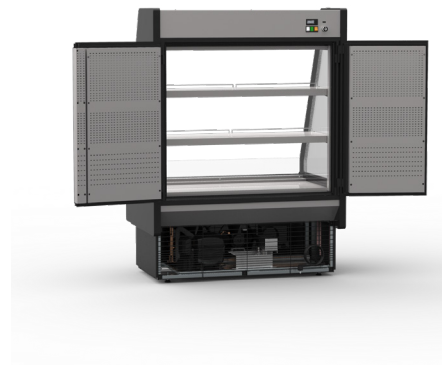

ELECTRIC SHUTTER



REAR LOADING

MODELS

KGL-RS-(40, 60)-S

KGL-RS-(40, 60)-R

GRAB-N-GO LOW PROFILE CASE FRONT AND REAR LOADING, ELECTRIC SHUTTER

CASE HOLDS 38°F TO 40°F • FORCED AIR REFRIGERATION • OPEN FRONT
FRONT AND REAR LOADING • KEY OPERATED ELECTRIC SHUTTER • TEMPERATURE RECORDER



AVAILABLE WITH A BLUE DECAL
*CONTACT OUR SALES DEPARTMENT FOR MORE INFORMATION



SELF CONTAINED	Model	O.A. Length (inches)	Volume FT ³	Electrical 115 Volts					NEMA 115 V Plug	Weight lbs		Crate Size (inches)			
				Front	Compressor		LIGHTS Fans HTRS	EVAP Pan		Total Amps	No Crate	With Crate	L"	W"	H"
					H.P	F.L.A									
	KGL-RS-40-S	41	12.98	5/8	8.9	1.29	6.7	16.8	5-20P	419	585	44	39	74	
	KGL-RS-60-S	60.6	19.85	3/4	16	2.35	6.7	25	HW	510	750	64	39	74	

REMOTE	Model	O.A. Length (inches)	115 Volts Total Amps	B.T.U	Weight lbs	
					No Crate	With Crate
	KGL-RS-60-R	60.6	1.4	5835	430	635

HW = Hard wired
Remote cases are hard wired

SPECIAL FEATURES

Locking back doors for rear loading
Key operated electric shutter

STANDARD FEATURES

Silver colored PVC coated steel front panel with a silver decal
CFC free injected foam insulation
PVC coated steel gray interior
Dark Gray anthracite kick plate
Foamed polystyrene black end panels
Tempered side glass
LED lighting in canopy and under shelves
Temperature and defrost regulated by a digital controller
Removable condensate evaporating pan for easy cleaning
Product stops on all shelves
Height adjustable, shelves can be tilted
Levelling feet

OPTIONAL FEATURES

Graphics on upper and lower front panels
Stainless steel exterior and / or interior
Other colors available
Additional shelves
Price tag molding
Product dividers
Condensate evaporating pan for remote cases
KGL-RS caster kit for self contained units only

WARRANTY

One year parts and labor with an additional four years on the compressor (part only)

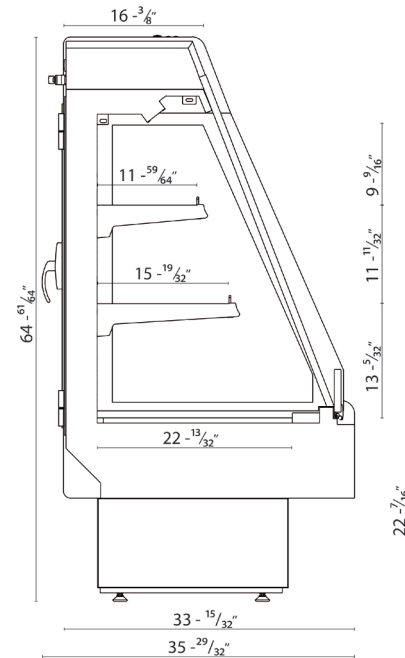

NOTE

These cases are engineered to operate in locations not exceeding 75°F and 55% R.H. These cases are designed to operate using R404a refrigerant. Alternate refrigerants available by special order. O.A. length includes (2) ends at 1-1/2" each. Ventilation grills at front and back cannot be blocked. B.T.U.'s are calculated at 14°F (evaporator) and 90°F (ambient). Remote cases are provided with an expansion valve and a liquid solenoid for pump down cycle. On remote cases, if no floor drain is provided, a condensate evaporating pan must be ordered and 6.7 amps added to the amp load. Remote cases must be hard wired – no plugs.

Tel: 786.600.4687 / Toll Free: 844.218.8477
Fax: 786.661.4100

Tel: 514.737.9701 / Toll Free: 888.275.4538
Fax: 514.342.3854 / toll free: 877.453.8832

06/2017 sales@mvpgroupcorp.com / mvpgroupcorp.com